



NEW MODEL 2016



YouTube  
Directly to the product video!



NEW:  
Foot brake

# Wheel balancer

Item No.: TW F-23

## Description

Automatic tyre balancing machine. TOP professional quality at an affordable price. Equipped with electric. Automatic probe arm for measuring rim distance and rim diameter. Automatic recognition of the balancing programs (Normal and Alu-S). Large digital 7.5 inch display.

## Features

- 1A Quality built with CE-Certificate
- Manufactured in accordance to ISO 9001
- Top design and robust technology
- Digital display 7.5 inches | Foot brake
- Automatic measurement with wheel breaking
- Static and dynamic balancing
- Several available programs Normal / Static / Alu1, Alu2, Alu3, Alu-S / Motorcycle etc.
- Integrated calibration and self-diagnostic program
- **Optional:** Motorcycle adapter, diverse vehicle adapter

## Delivery contents

- Wheel balancer TW F-23
- Centering cones (4 pcs.) gauge, weight pliers
- Quick release nut
- Calibration weight
- English instruction manual and CE-Certificate

## Details

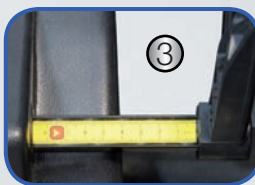

(1) 15 storage compartments (2) Accurate targeted mounting of all the weights using the electronic caliper arm (3) Integrated distance measurement (4) Quick release nut  $\varnothing = 40$  mm (5) Digital Display (The new, compartment design ensures maximum user comfort and optimal ergonomics)

## Dimensions | Technical Data | Accessories

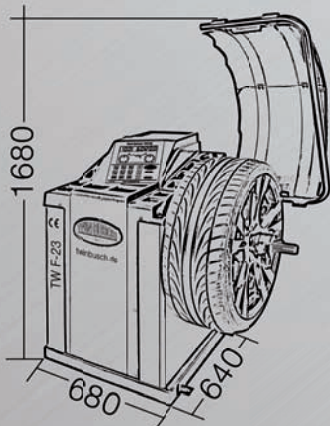

Extensive accessories

Technical Data: TW F-23	
Wheel width	1,5" - 20"
Wheel diameter	10" - 24"
Wheel weight max.	65 kg
Wheel center hole	40-135 mm
Measuring tolerance	+/- 1 g
Measuring time (approx.)	4-7 sec.
Power supply	230 V~
Noise level	< 70 dB
Weight (approx.)	123 kg