

PROXXON MICROMOT.

THERMOCUT 12/

5
: 12V; 50/60 Hz
: 60W
150° -400°
-1
: 0,85
: 200
: 100
: 200

PROXXON-MICROMOT 2.0

400°

- 1. -1
- 2.
- 3. -1.
- 1. -1
- 2.
- 3. -1.
- 1. -1
- 2. -2
- 3. -1

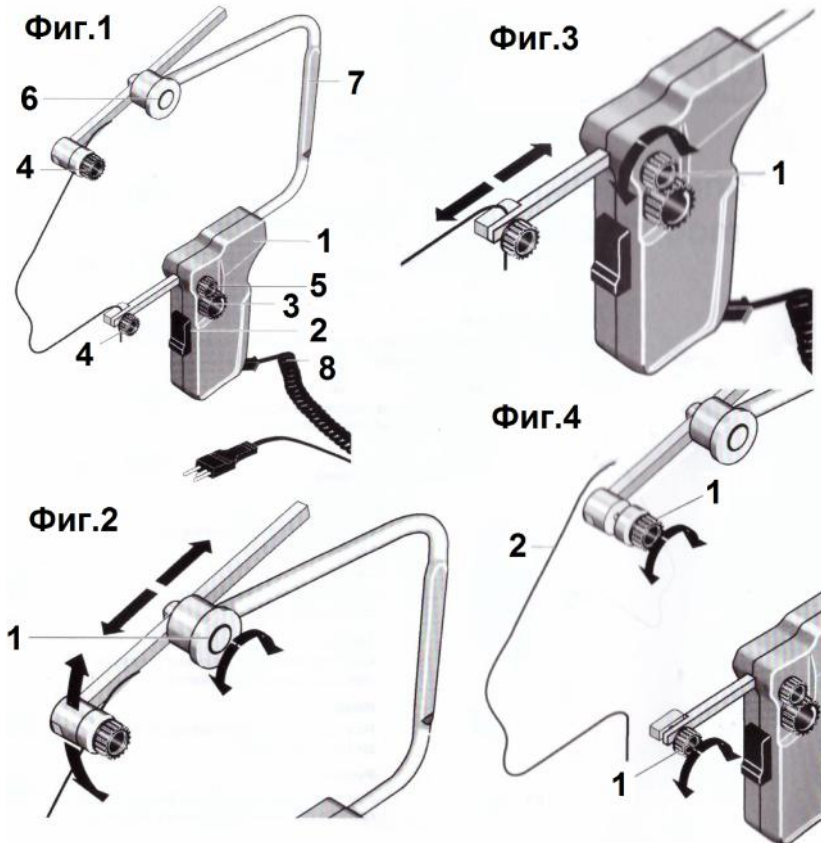

PROXXON MICROMOT.

THERMOCUT 12/

5
: 12V; 50/60 Hz
: 60W
150° -400°
-1
: 0,85
: 200
: 100
: 200

PROXXON-MICROMOT 2.0

400°

- 1. -1
- 2.
- 3. -1.
- 1. -1
- 2.
- 3. -1.
- 1. -1
- 2. -2
- 3. -1

